

# Surface Mount LED Canopy Fixture



## PRODUCTS DESCRIPTION

The CPSM Series surface mount LED canopy is a utility ceiling-mount fixture for general lighting applications in parking garages, designed for easy installation and maintenance. The CPSM Series LED canopy delivers High lumens, accepts 100-277VAC/347-480VAC, consumes 40/60/90 watts and produces luminous intensity equivalent to 175W/250W/400W metal halide. Available in motion sensor option, the CPSM LED canopy will further save energy during application.

## CONSTRUCTION & MATERIALS

- One-piece die-cast aluminum housing
- One-piece silicone perimeter lens gasket and closed-cell neoprene housing gasket help to seal out moisture and contaminants
- High quality shock proof polycarbonate lens with UV inhibitors
- Integral secondary heat sink to optimize thermal transfer and maximize performance and life of LED
- Driver is mounted in direct contact with the casting for a low operating temperature and long life
- Polyester powder-coated finish, rust and corrosion proof

## MOUNTING AND WIRING

- Three 3/4" mounting holes plus one on top for mounting. One installation bracket with screws are supplied in package

## ENVIRONMENTAL SYSTEM

- ETL/cETL listed for outdoor locations

## ELECTRICAL SYSTEM

- Integral high performance LED driver
- Universal input voltage 100-277VAC or 347VAC-480VAC, 50/60Hz

## OPTICAL SYSTEM

- High quality shock proof polycarbonate lens with UV inhibitors
- Extremely wide lighting distribution
- High performance LM80 SMD LEDs
- Color temperature: 5000K. Other color temperature available for special order, consult factory for lead time

## LIGHTING CONTROL

- 0-10V dimmable/photocell/motion sensor options

## SPECIFICATIONS

ITEM	SPECIFICATION	KTWL5302-40-H	KTWL5302-60-H	KTWL5302-90-H
		KTWL5302-40-L	KTWL5302-60-L	KTWL5302-90-L
GENERAL PERFORMANCE	Power consumption(W)	40W	60W	90W
	Lumens Delivered (lm)	4400-4800lm	6600-7200lm	9900-10800lm
	Efficacy (lm/W)	110-120lm/w		
	CRI	>70		
	Color Temperature	3000K/4000K/5000K		
	L70	More than 50000hours		
	Power Factor	0.98 at 120VAC 0.90 at 277VAC/347-480VAC		
ELECTRICAL	Input Voltage	100-277VAC/347-480VAC		
PHYSICAL	Housing	die-cast aluminum body(Bronze/Black). PC diffuse		
	Installation	Recessed outlet box or wall surface		
	Operating temperature	-30°C Up to 50°C (-22°F up to 122°F).		
CERTIFICATION	Environment	Suitable for damp/wet locations		
	Warranty	5 years		
	Certification	ETL/cETL,DLC		

## DIMENSIONS

KTWL5302-40 -H/ KTWL5302-40-H

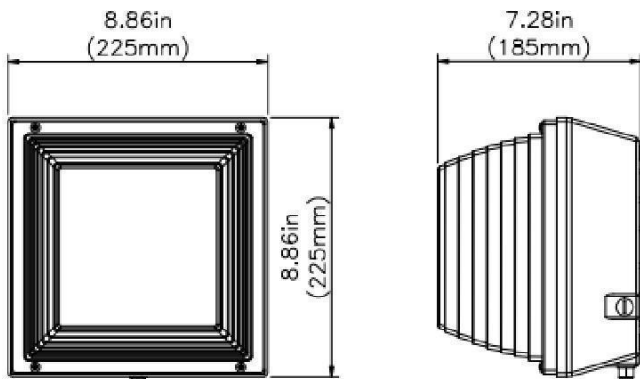

KTWL5302-40 -L/ KTWL5302-40

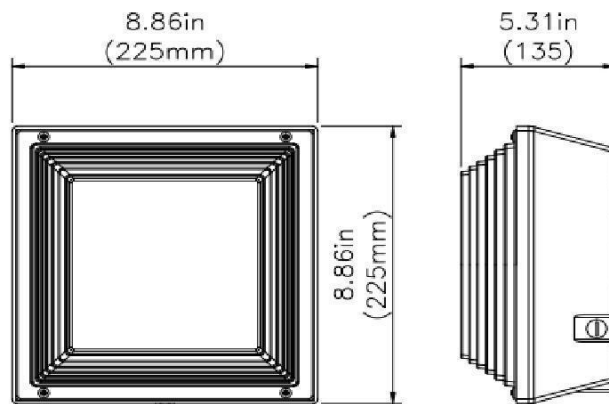

KTWL5302-60-H/ KTWL5302-90-H/KTWL5302-60-L/ KTWL5302-90-L

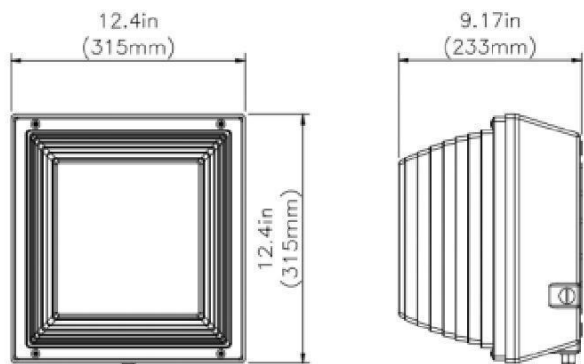

KTWL530260-L/ KTWL5302-90-L /KTWL5302-60-L/ KTWL530290-L

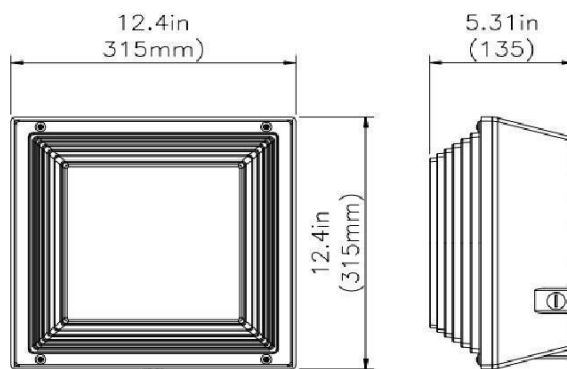

## ORDER INFORMATION

For example (KLCPSM40-H-30KS00)

Family	Wattage	Separator	Thickness	Separator	CCT	Version	Label	Default
<b>KTWL:</b>  Surface Mount LED Canopy(100- 277VAC)  <b>KTWL:</b>  Surface Mount LED Canopy (347-480VAC)	<b>40 :</b> 40W <b>60 :</b> 60W <b>90:</b> 90W	-	<b>H:</b> High Cover  <b>L:</b> Low Cover	-	<b>30K:</b> 3000K <b>40K:</b> 4000K <b>50K:</b> 5000K	<b>S :</b> Standard <b>P:</b> platinum	<b>0 :</b> KILI-LED Label  <b>1:</b> Customized Label	<b>X</b>

## PACKAGING:

Product No.	Pieces/carton	NW	GW	Box dimensions
KTWL5302-40-H	8pcs	17.6kg(38.8lb)	19.5kg(43.0lb)	52*52*47cm
KTWL5302-60-H	4pcs	16.6kg(36.6lb)	18.2kg(40.1lb)	68.5*35.5*54cm
KTWL5302-90-H	4pcs	16.8kg(37.0lb)	18.5kg(40.7lb)	68.5*35.5*54cm
KTWL5302-40-L	8pcs	12.4kg(27.2lb)	14.2kg(31.3lb)	49*49*30.5cm
KTWL5302-60-L	4pcs	14.6kg(32.2lb)	16.8kg(37.0lb)	68.5*35.5*34cm
KTWL5302-90-L	4pcs	15.0kg(33.0lb)	17.5kg(38.6lb)	68.5*35.5*34cm

Copyright: Kontak LIGHTING  
 Updata:2019-08-24